

# Vernier Caliper

## SERIES 530 — Standard Model

### FEATURES

- Can measure OD (outside diameter), ID (inside diameter), depth, and steps.
- The small vernier face angle ( $14^\circ$ ) provides easy reading.
- Dual reading scales on vernier. (metric/inch and inch models only)
- Lock screw for holding the sliding jaw position.
- Carbide-tipped jaw type calipers are also available.
- Supplied with vinyl holster in fitted carton. Except 24" / 600mm models are carton only. 40" / 1000mm supplied in wooden case.

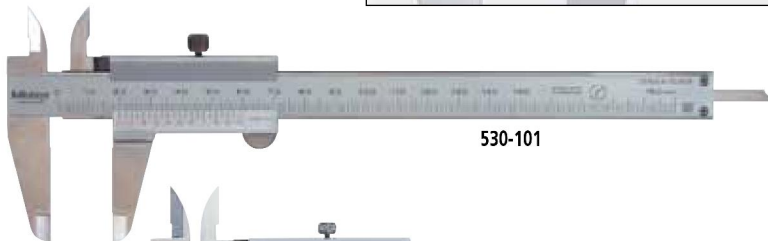
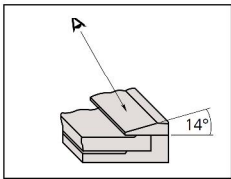

530-101

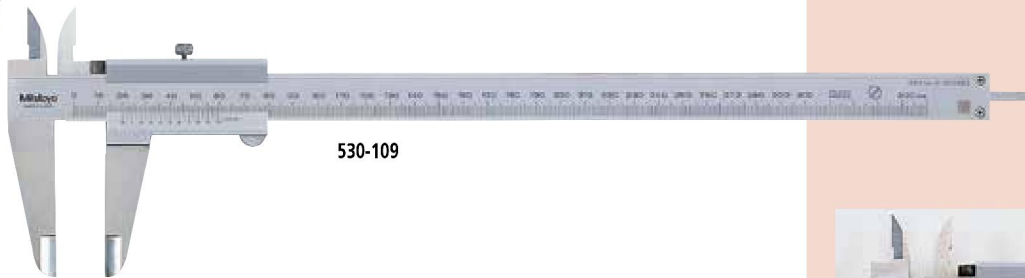

530-109

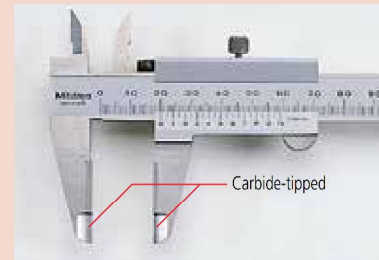

Carbide-tipped jaw type

### DIMENSIONS AND MASS

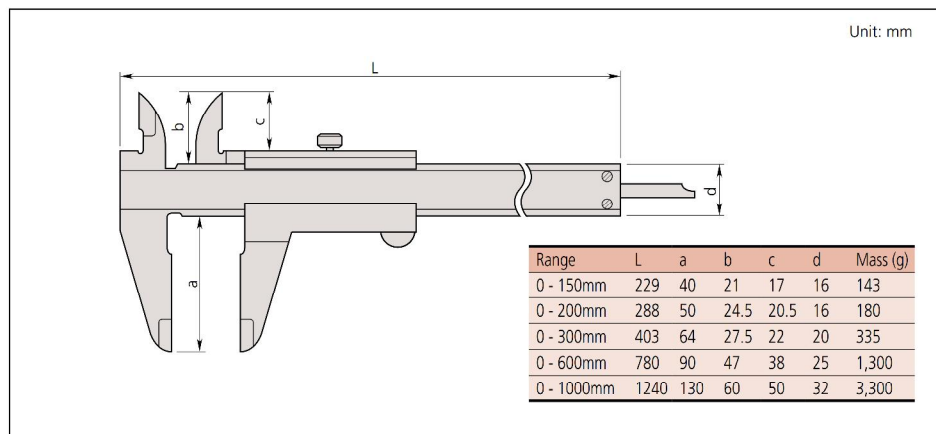

Round depth bar type

## "Quadri" (4 way) Measurement Measurement Applications

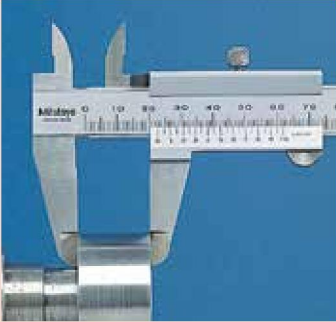

OD measurement

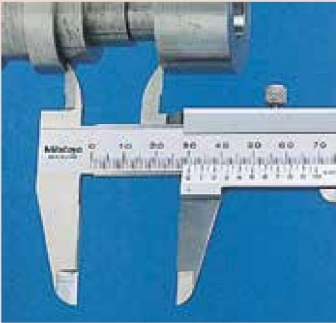

ID measurement

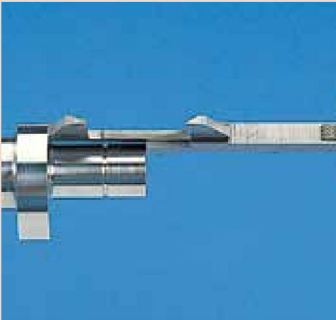

Step measurement



Depth measurement

## SPECIFICATIONS

### Metric

Range	Order No.	Accuracy	Graduation	Remarks
0 - 150mm	<b>530-102</b>	±0.05mm	0.05mm	∅ 1.9mm Depth bar
0 - 150mm	<b>530-101</b>	±0.05mm	0.05mm	—
0 - 150mm	<b>530-320</b>	±0.05mm	0.05mm	Carbide-tipped jaws for OD measurement
0 - 150mm	<b>530-335</b>	±0.05mm	0.05mm	Carbide-tipped jaws for OD & ID measurement
0 - 150mm	<b>530-122*</b>	±0.03mm	0.02mm	High accuracy model
0 - 200mm	<b>530-108</b>	±0.05mm	0.05mm	—
0 - 200mm	<b>530-321</b>	±0.05mm	0.05mm	Carbide-tipped jaws for OD measurement
0 - 200mm	<b>530-123*</b>	±0.03mm	0.02mm	High accuracy model
0 - 300mm	<b>530-109</b>	±0.08mm	0.05mm	—
0 - 300mm	<b>530-322</b>	±0.08mm	0.05mm	Carbide-tipped jaws for OD measurement
0 - 300mm	<b>530-124*</b>	±0.04mm	0.02mm	High accuracy model: ±0.04mm
0 - 600mm	<b>530-501**</b>	±0.1mm	0.05mm	—
0 - 1000mm	<b>530-502 **</b>	±0.15mm	0.05mm	—

\*Graduation: 0.02mm

\*\*No depth measuring bar

### Metric/Inch with metric/inch dual scale

Range	Order No.	Accuracy	Vernier Graduation		Remarks
			Lower Scale	Upper Scale	
0 - 150mm / 0 - 6"	<b>530-104</b>	±0.05mm	0.05mm	1/128"	—
0 - 150mm / 0 - 6"	<b>530-316</b>	±0.05mm	0.05mm	1/128"	—
0 - 150mm / 0 - 6"	<b>530-312*</b>	±0.03mm	0.02mm	.001"	High accuracy model
0 - 200mm / 0 - 8"	<b>530-114</b>	±0.05mm	0.05mm	1/128"	—
0 - 200mm / 0 - 8"	<b>530-118*</b>	±0.03mm	0.02mm	.001"	High accuracy model
0 - 300mm / 0 - 12"	<b>530-115</b>	±0.08mm	0.05mm	1/128"	—
0 - 300mm / 0 - 12"	<b>530-119*</b>	±0.04mm	0.02mm	.001"	High accuracy model

\*Graduation: 0.02mm

### Inch with inch/inch dual scale

Range	Order No.	Accuracy	Vernier Graduation		Remarks
			Lower Scale	Upper Scale	
0 - 6"	<b>530-105</b>	±.0015"	.001"	1/128"	—
0 - 8"	<b>530-116</b>	±.0015"	.001"	1/128"	—